

CABINET LOADING DEVICE

TECHNICAL SPECIFICATIONS

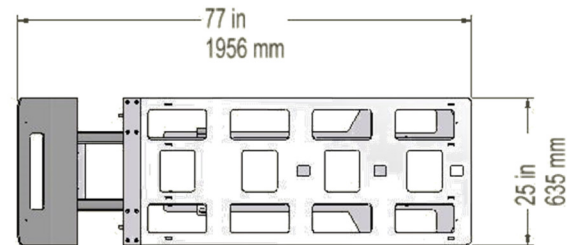
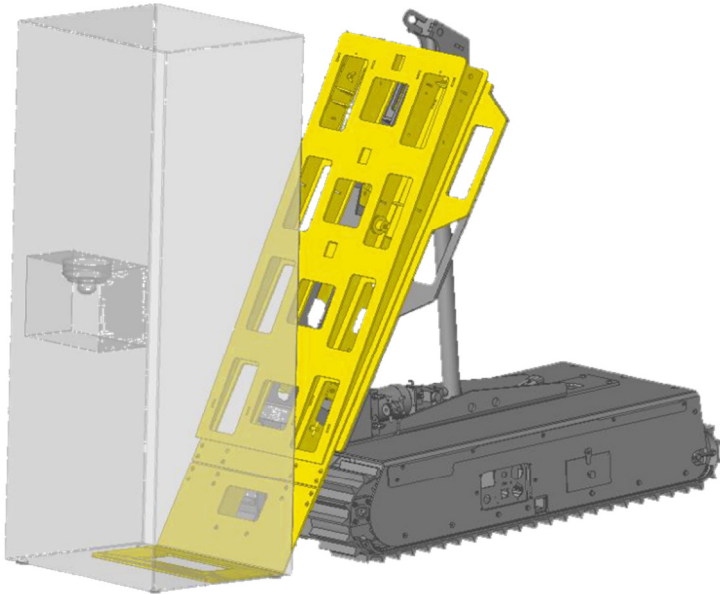

PHYSICAL CHARACTERISTICS

Material	Aluminum and steel	
Length	77 in	1956 mm
Width	25 in	635 mm
Height	16 7/8 " in	572 mm
Weight	142 lb	65 kg
Load bearing capacity* (inclined surface)	658 lb at 35°	299 kg at 35°
Load bearing capacity* (on stairs)	658 lb at 35°	299 kg at 35°
Load bearing capacity* (flat surface)	988 lb	449 kg

COMPATIBLE WITH :

- Lifting device 62°

* These load bearing capacities have been tested with a Twin-Track 66 model. Contact your dealer to know the load bearing capacities of this accessory when it is used with other Track-O models.

The information contained in this document is subject to change without notice.